

Application Number	22/1285/FFU
Address	Unit 9 Stanhope Road Camberley Surrey GU15 2BW
Proposal	Demolition of existing two-storey building and construction of a three-storey building to facilitate a change of use from B1c (light industrial) to a car mechanic and body workshop, showroom and sales suite, office and car park (Sui Generis)
© Crown copyright and database right. All rights reserved (100018679) 2023	

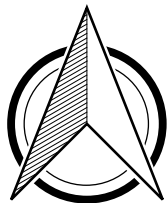

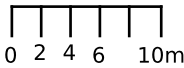

Scale @ A4	
Date	27/03/2023
